

# FLONEX

---

## PTFE EXPANSION JOINT



F L O N E X



# FLONEX

## PTFE EXPANSION JOINT



### Features

- PTFE EXPANSION JOINT**  
 PTFE expansion joint has the best features of chemical resistance, heat resistance, thermal stability, non-adhesive, weather resistance and high resistance to physical fatigue. TOZEN recommends FLONEX for today's piping systems.
- HIGH CHEMICAL RESISTANCE**  
 PTFE has high chemical resistance to every chemical except fluorine gas (CIF3 & OF2) and fusing alkali metal. Therefore, FLONEX is suitable for various acids, alkalines and solvents.
- HEAT RESISTANCE AND THERMAL STABILITY**  
 FLONEX can afford a wide working temperature range from -20°C to +130°C.
- NON-ADHESIVITY**  
 FLONEX has high non-adhesivity. Therefore, FLONEX is applicable to sticky fluids. Inside of FLONEX can be also cleaned easily.
- WEATHER RESISTANCE**  
 FLONEX can be used in outdoor for a long period without any aging deterioration.
- EXCELLENT FLEXIBILITY**  
 Owing to our special hydraulic forming, FLONEX has smaller thickness difference than other Teflon bellows. FLONEX provides the maximum flexibility for expansion compensation, vibration and sound absorption in a very short length. Since PTFE contains no carbon element, no electrolysis will be generated. It is specially recommended for the use of potable water and demineralized water.

### Applications

Chemical Processing Industries, Water Treatment Plant, HVAC Systems and other industries.

### Structure

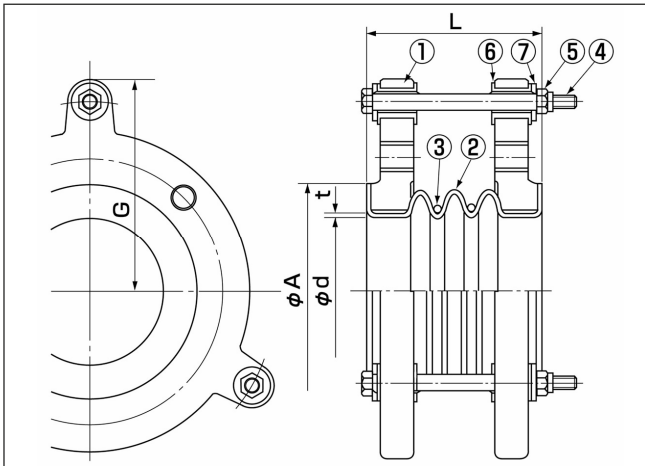

No.	Parts	Materials
①	Flange	FCD450/SS400
②	Bellows	PTFE
③	Control Ring	SUS304
④	Limit Bolt	SS400
⑤	Nut	SS400
⑥	Grommet	Synthetic Rubber
⑦	Flat Washer	SS400

• Flanges on ANSI, BS, etc. are available. The flange material can be changed to SUS304. Please consult us.

### Installation Bolts

Please use the following limit bolts for installation.

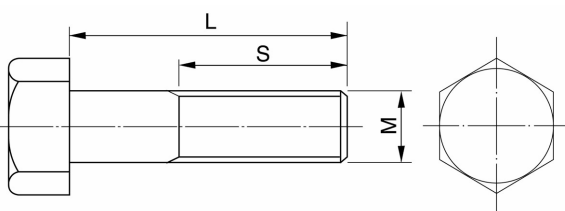

JIS B 0205 (Metric Coarse Screw Thread)

Nominal Dia.(A)	Installation Bolt Size (mm)	Nominal Dia.(A)	Installation Bolt Size (mm)
20	M12x35L	100	M16x50L
25	M16x35L	125	M20x60L
32	M16x40L	150	M20x60L
40	M16x40L	200	M20x65L
50	M16x45L	250	M22x70L
65	M16x45L	300	M22x70L
80	M16x50L	-	-

Data are based on the thickness of JIS10K standard flanges and gaskets are not included.

## • Dimension and Allowable Movement

Nominal Dia. (A)	Dimension (mm)					Mass (kg)	Allowable Movement (mm)				Installation Tolerance (mm)			
	L	ØA	Ød	t	G		T.M.	A.E.	A.C.	A.M.(°)	T.M.	A.E.	A.C.	A.M.(°)
20	44	50	25	1.5	155.0	1.3	6	13	13	14	3	3	3	5
25	44	50	25	1.5	166.2	1.6	6	13	13	14	3	3	3	5
32	49	62	32	1.5	176.2	1.8	6	13	13	14	3	3	3	5
40	51	73	38	1.5	181.2	2.0	6	13	13	14	3	3	3	5
50	68	92	49	2.0	202.6	3.1	10	19	19	14	4	3	3	5
65	77	105	63	2.0	229.0	4.1	10	19	19	14	4	3	3	5
80	85	120	73	2.0	242.2	4.2	13	25	25	14	5	5	5	5
100	85	145	97	2.5	257.6	5.9	13	25	25	14	5	5	5	5
125	100	175	119	2.5	319.9	11	13	25	25	14	5	5	5	5
150	100	205	145	2.5	349.9	13	14	29	29	14	6	6	6	5
200	133	255	196	2.5	393.6	19	14	29	29	14	6	6	6	5
250	170	315	244	3.0	469.8	25	14	29	29	14	6	6	6	5
300	190	360	292	3.0	528.0	30	14	29	29	14	6	6	6	5

T.M. = Transverse Movement  
A.E. = Axial Elongation  
A.C. = Axial Compression  
A.M. = Angular Movement

- Mass indicates only the case of JIS 10K flanges.
- Use the products within the given allowable movements.
- Installation tolerances are included in the allowable movements.  
(Allowable movements = Tolerances for installation + Operating movements)
- Please note that information in the above table are for single movement only. In case of complex movements, some correction is required.

## • Operating Condition

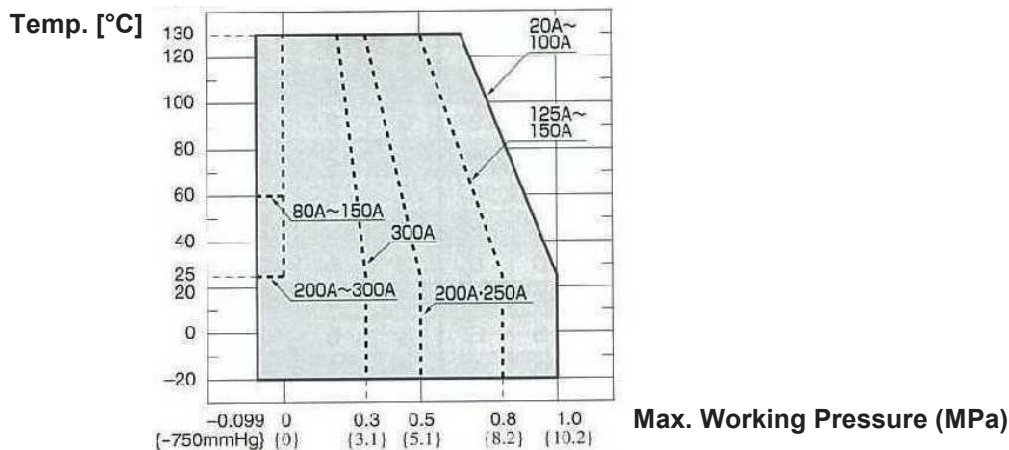

## • Notes

- Information in the above table is for single movement only. In case of complex movements, follow the below expression.

$$C.EL(C) = A.EL(C) \times \left\{ 1 - \frac{(A.T.M. - T.M.) \times (A.A.M. - A.M.)}{A.T.M. \times A.A.M.} \right\}$$

C.EL(C) = Correct Elongation (Compression)  
A.EL(C) = Allowable Elongation (Compression)  
A.T.M. = Allowable Transverse Movement

T.M. = Transverse Movement  
A.A.M. = Allowable Angular Movement  
A.M. = Angular Movement

- Install the joint according to the above given allowable dimensions.

## • Tightening Torque for Installation Bolts

Please tighten the installation bolts with the following torque.

Nominal Dia. (A)	Tightening Torque N·cm (kgf·cm)	Nominal Dia. (A)	Tightening Torque N·cm (kgf·cm)
20-25	1764 (180)	125	6566 (670)
32-40	2450 (250)	150	8134 (830)
50	3430 (350)	200	6566 (670)
65	4018 (410)	250	9506 (970)
80	2646 (270)	300	7840 (800)
100	4018 (410)	-	-

## • Installation Instructions

- All pipe lines should be properly supported so that the expansion joints do not carry any pipe load.
- Do not remove the protecting board attached to the FLONEX until actual installation. If the protecting board is removed for a long time, the flare face of the joint may curve irregularly. Meanwhile, dust, dirt or other foreign objects may enter into the bellows.
- Clean the flare face of the expansion joints. Remove all dirt, burrs and sharp edges from the counter flanges by means of file or sandpaper.
- Bolts should not stuck out more than 3mm. from the reverse side of the flanges.
- Bolts should be tightened equally by alternating around the flange.
- Limit bolts and nuts are pre-set. Do not remove or adjust without any specific instructions.
- Clean all foreign objects from the corrugation of the bellow, especially any objects found around the control rings.
- Any detachment of the expansion joints must be performed under 100°C. Attach the protecting board to the flare face of the bellow.
- Pay attention to protect the expansion joints from damage by heat or welding sparks.
- Limit bolts are pre-set at the factory to fix the maximum overall length of FLONEX. In case the limit bolts are used as tie rods in the condition of insufficient pipe support, please apply them under the following pressure as maximum pressure.

Nominal Dia.(A)	Max. Pressure (Mpa) 3-Bellows
20	1.0
25	1.0
32	1.0
40	1.0
50	1.0
65	1.0
80	1.0

Nominal Dia.(A)	Max. Pressure (Mpa) 3-Bellows
100	1.0
125	0.8
150	0.8
200	0.5
250	0.5
300	0.3
-	-

All details are subject to change without prior notice.

**TOZEN (THAILAND) CO., LTD.**  
 3388/62 18TH FLOOR, SIRINRAT BLDG.,  
 RAMA IV Rd., BANGKOK 10110 THAILAND  
 TEL : (66) 0-2367-5721-8  
 FAX : (66) 0-2367-5729, 0-2367-5066  
 E-MAIL : sales@tozen.co.th  
 URL : www.tozen.co.th

**TOZEN CORPORATION.**  
 8-4, ASAHY YOSHIKAWA  
 SAITAMA 342-008 JAPAN  
 TEL : 048-993-1030  
 FAX : 048-993-1038