



## Features

- Reflex level gauge applicable upto 200 kg and upto 400 deg cent
- Cryo applications upto -196deg cent
- Toughened borosilicate glass with serrations
- For applicability in critical, acidic, cryo and temperature zone
- IBR certified device available
- NACE, H2S service compatibility applicable
- Non frost extension
- Heat tracing available
- Level 1 radiographed body available
- Helium leak test proved design @ 10(-7) mbarlt/sec
- Viscous media (max upto 380 cst and upto 100 deg cent) besides other acidic, non acidic, steam water media
- CE applicability
- Applicable for refinery, petrochemical, chemical, power, radioactive, fertilizer, food, pharma, metal industry applications

## Concept and Principle of operation

Liquid Level Gauge provides direct observation of liquid level in a tank/vessel rising and falling level of the liquid inside the tank/vessel can be observed through the glass assembled in the gauge.

Reflex Liquid Level Gauges use the R-form sight glasses. One side surface of Reflex Glass to use flat glass has several grooves for reflecting prism. The principle of the Reflex Glass is based on the difference in the refractive indices of liquid and gas or in particular of water and steam. Liquid level shows conspicuously dark hard color fro liquid space and light white color for empty space. These Reflex series are not used with a mica shield. The Reflex Gauge is assembled firmly with gasket, reflex glass, cushion gasket and gauge cover on the body by U-bolts.

Reflex Liquid Level Gauges, designed and built for a wide range of high temperature and high pressure applications. Our reflex level gauge is used to make, besides other applications include observation of the level of corrosion-proof and chromatic liquids. The most advantage of this type is for easy level reading of boiling liquids. When liquids are boiling, their bubbles make the surface level indistinct. The manual adjustment of isolation valve at the input of the media entering the chamber reduces the bubbling. Therefore the level gauge ease to read the level or bubbling liquids. It also provides advantages for highly dense and viscous liquids, as the body is made of forged construction only.

This level gauge is designed and manufactured for easy and accurate reading the liquid level of highly foamy liquids. The gauge has a relatively spacious internal area where foamy liquid is held from forming foams.

## Sealing gaskets, Cushions and Glasses



Sealing gaskets and cushions for tight sealing at rated pressure and temperature. Tight sealing PTFE with glass inserted, GFT and SS316 impregnated in graphite are the special features of the gaskets General Instruments Consortium provides.

### Special Application

If a conventional level gauge is used for extreme low temperature applications, it becomes difficult to observe the level of liquid as the gauge front tends to freeze. To get rid of this problem, an acrylic non-frosting plate is mounted in front of the gauge. So the observation of the liquid level is much easier this way.

Our Non-Frosting Reflex Level Gauges are classified depending on the process temperature, the height of the non-frosting plate window may be selected from 80 to 250 mm.

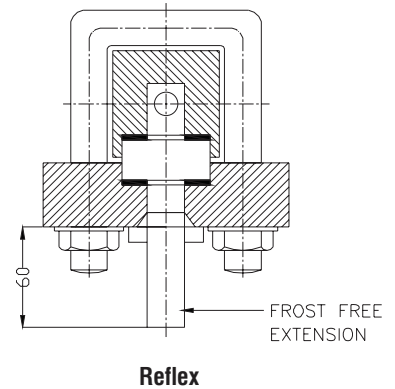

### Special Application

For a jacket type requirement application. This gauge is used to read the level of high congealable or ebullient liquids. The principle is to inflow a steam for congealable liquids and a cold water for ebullient liquids through the inside of the jacket to ensure accurate and reliable level observation.

This type is used for observing the fluid by changing it into state of liquid after heating or cooling it through jacket according to fluid's features. Our standard is that the inlet of the jacket for steam or cold water is 1/2" NPT(M) and or 15 NB flange. Others are available on request.



### Special Application

More severe demands may often be required on liquid level gauges in terms of resistance to corrosion, and this is accomplished by lining or coating all wetted parts. The most important aspect of this process is the preparation of the metal substrate.

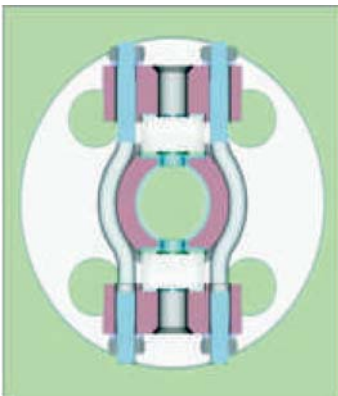

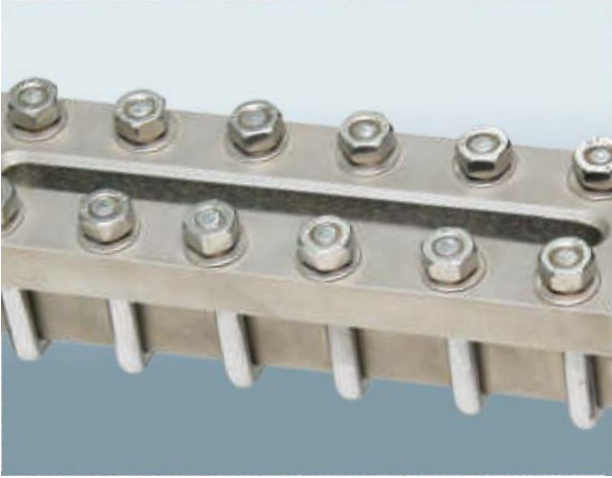

High tensile U Bolts to handle high pressure upto 200kg working pressure and high temperature upto 320 deg cent application



Reflex level gauge at 150# rating at 125 deg cent and FF end connection with auto ball check valve and drain valves in Polypropylene material

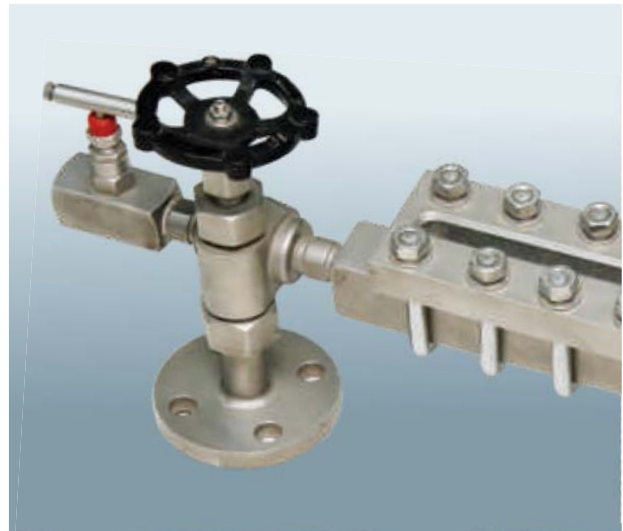

Needle, ball and globe valves upto 1500# at various applicable material suitable to pressure and temperature and media all in forged construction and IBR approved

### Technical Specifications: Table-1 Material of Construction

<b>Type</b>	Reflex
<b>Liquid Chamber</b>	Carbon steel, SS304, SS304L, SS316, SS316L, Monel, Titanium, Inconel 600, Hastelloy C, PolyPropylene, others on request, subject to Pressure and temperature condition
<b>Cover plate</b>	Carbon steel, SS304, SS304L, SS316, SS316L, Monel, Titanium, Inconel 600, Hastelloy C, PolyPropylene
<b>Cushion</b>	CAF, PTFE
<b>Gasket</b>	CAF, PTFE, Grafoil
<b>Fastners</b>	SS, ASTM A 193 Gr B7
<b>Scale</b>	Alluminium and SS engraved in mm
<b>Glass</b>	Klinger/Ilmadur applicable till 320 deg cent as per DIN 7080/7081, BS 3463, JIS B 8211, Toughened Borosilicate glass

**Technical Specifications: Table-2 Technical data**

<b>Borosilicate glass</b>	Upto 400 deg cent
<b>Toughened glass</b>	Upto 150 deg cent
<b>Glass thickness</b>	17 mm
<b>Glass width</b>	30 mm
<b>Glass dimensions type</b>	250 mm and 340 mm
<b>Operating pressure applicable as input</b>	100 kg, higher depending on temp
<b>Shell test applicable, pressure</b>	200 kg at 20 deg cent
<b>Shell test applicable, temperature</b>	Max 400 deg cent depending on selected MOC
<b>Cryo applicability applicable (non frost at the glass)</b>	Max upto 200 kg and upto -194 deg cent
<b>Cushion and gasket thickness</b>	1.5 mm applicable for -194 deg cent to upto 400 deg cent against suitable MOC
<b>Centre to centre distance</b>	Max upto 3000 mm applicable with desired accuracy and visibility
<b>Vent/drain</b>	½" plugged / ½" needle valve / ½" ball valve / ½" globe valve
<b>Process connection</b>	15 to 50 mm flanged / upto 25mm screwed / socket weld and others on request

**Technical Specifications: Table-3 Temp rating and dimensions of non-frosting plates**

<b>Temperature °C</b>	0...-20	-21...-45	-46...-100	-101...-160	-161...-200
<b>Recommended Materials</b>	LTCS	LTCS	304SS	316SS	316LSS
<b>Acrylic Height mm</b>	80	100	150	200	250

**Technical Specifications: Table-4 Visible Length According to Sections**

<b>Sr. No.</b>	<b>Visible Length (of level gauge) in mm</b>	<b>No. of Sections VI (glass length = 250 mm)</b>	<b>No. of Sections IX (glass length = 340 mm)</b>
1	230	1	0
2	320	0	1
3	495	2	0
4	585	1	1
5	675	0	2
6	760	3	0
7	850	2	1
8	940	1	2
9	1030	0	3
10	1115	3	1
11	1205	2	2
12	1295	1	3
13	1385	0	4
14	1470	3	2
15	1560	2	3
16	1650	1	4
17	1740	0	5
18	1825	3	3
19	1915	2	4
20	2005	1	5
21	2095	0	6
22	2180	3	4
23	2270	2	5
24	2355	5	3
25	2445	4	4
26	2535	3	5
27	2625	2	6
28	2715	1	7
29	2805	0	8
30	2890	3	6
31	2980	2	7

**Technical Specifications: Table-5 Indicative weights in kgs**

Transparent level guage visible length in mm	With isolation valve (upto 1" RF flange) and with handle with drain and vent plug (upto 300# body)	With isolation valve (upto 1" RF flange) and with handle with drain and vent plug (600# body)	With isolation valve (upto 1" input) and with handle with drain and vent plug (900# & 1500# body)	Add on for heating jacket	Add on for frost extension	Add on for ball valve replacing the drain & vent plug
320	13	20	38	1	0.5	2
585	23	35	63	2	1	2
1030	48	72	120	3	1.5	2
1915	70	110	On request	5	2.5	2
2980	120	On request	On request	9	4.5	2

**Construction and dimensional cross sectional overview**

The gauge consists of a body having machined to have a liquid where high temperature are liable to occur, the glass is toughened borosilicate glasses are used. These reflex gauges preferably used for reservoir tanks that require a relatively long visible length by constructing the supporter.

The reflex level gauge is assembled firmly with gasket, reflex glass, cushion gasket and gauge cover on the body by U bolts.

The most advantage of this type is that it has no invisible sections (dead band). Our standard overlapped section is 10 mm as minimum and the gauge is so designed that supporting brackets can be equipped to protect a long multiple connected gauge from distortion of fall down. The scale plate to mount alongside the gauge may be available on request by customers to observe the liquid level more accurately.

The gauge is used with a special reflex type gauge glass which has wider V-shaped refractive groove and red coating on the outside of the glass. It provides a clear observation of liquid level because of made refracting red colour on th V-groove for steam or beyond portion of the level and it's colour of fluid itself for liquid portions.

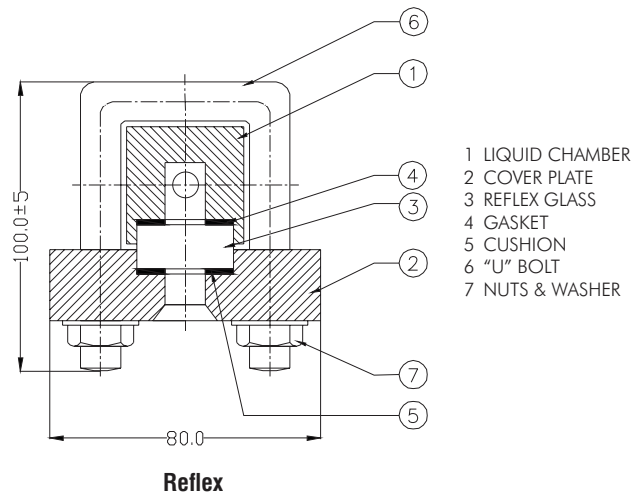

**Process Orientation**

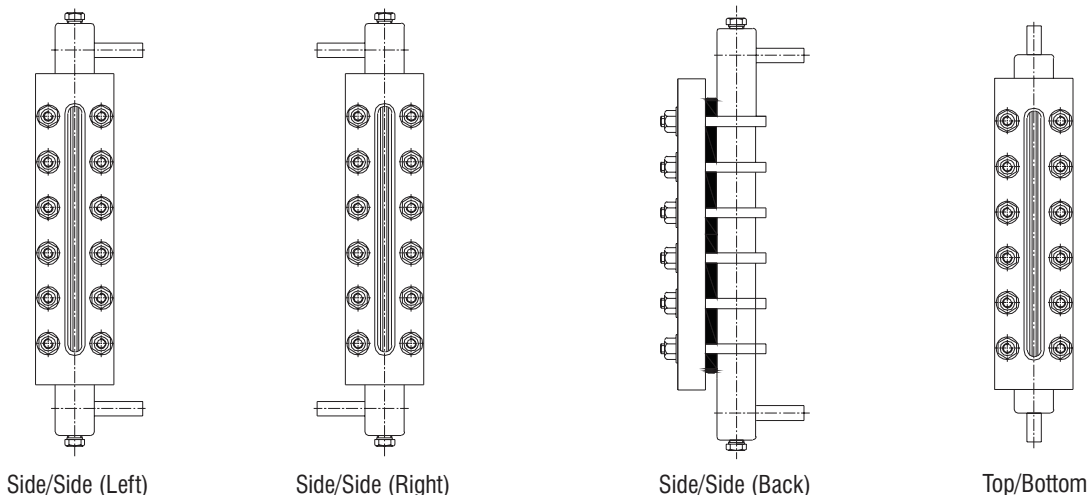

**Orientation of Process Connection**

## Process Orientation

Transparent Gauges manufactured by GIC will provide at ease the orientation as per your convenience to have the maximum visibility with respect to process changes i.e. level, isolation valve settings, whether any kind of leakages, leakages through plugs for vent and drain, settings for needle/ball valves.

All orientations at your process suitability with optimum results

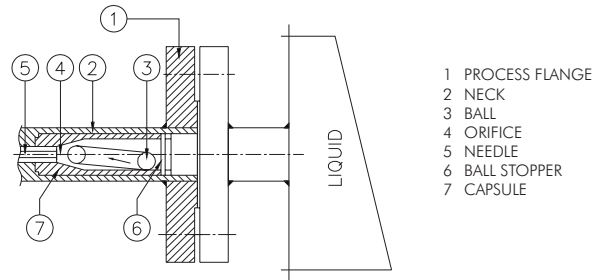

**Auto Ball check arrangement for suitability on level optimization/leakage**

- 1 PROCESS FLANGE
- 2 NECK
- 3 BALL
- 4 ORIFICE
- 5 NEEDLE
- 6 BALL STOPPER
- 7 CAPSULE

## Isolation Valve

Bolted and screwed bonnet offset construction to attain device durability, high stability, low hysteresis, high leakage class, bolted bonnet construction for high temperature and pressure, all construction in forged only with the best level 1 radiographed and attain high leakage class of 10(-5) mbar lt/sec.

Screwed connection for low temperature and pressure with full forged construction and with best of level 1 radiography and attain high leakage sealing class of 10(-4) mbar lt/sec.

Ordering information

We require for a complete level solution the following data:

- The pressure
- The level that you need to measure
- The temperature
- The media name
- The density
- The media colour in normal eye
- The viscosity

Rest leave it us for an engineering sizing and selection to provide a optimum level gauge.

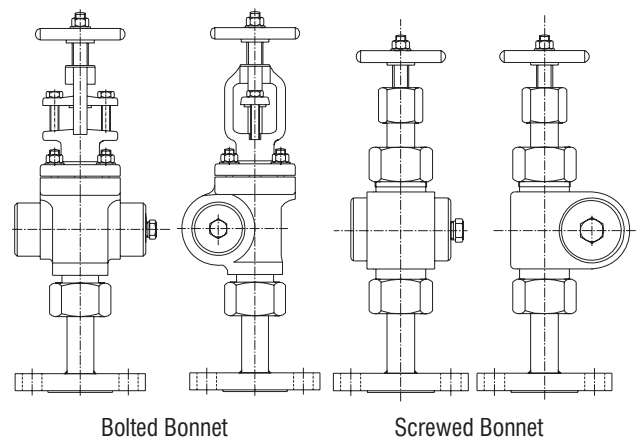

**Bolted Bonnet**

**Screwed Bonnet**

**Isolation Valve**

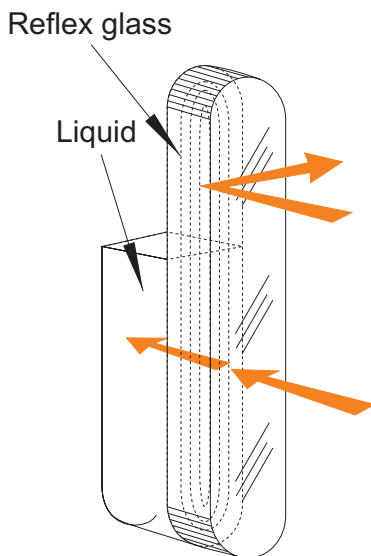

**Principle of reflex level glass**

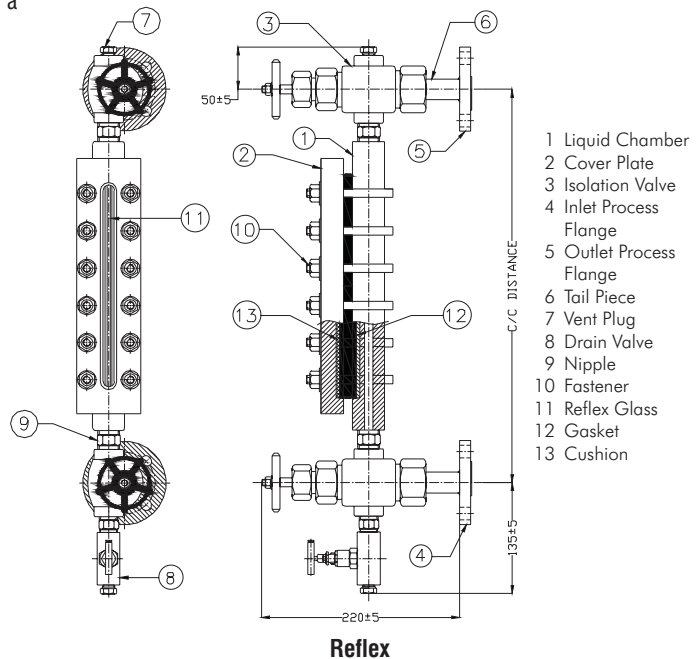

**Reflex**

- 1 Liquid Chamber
- 2 Cover Plate
- 3 Isolation Valve
- 4 Inlet Process Flange
- 5 Outlet Process Flange
- 6 Tail Piece
- 7 Vent Plug
- 8 Drain Valve
- 9 Nipple
- 10 Fastener
- 11 Reflex Glass
- 12 Gasket
- 13 Cushion

Basic GA drawing indicating the top bottom design with CCD interface with visible length. The distance between coverplate and bolted bonnet offset construction is 70mm and that of screwed bonnet is 80 mm. The glass edge is approx 8mm more in each case against the isolation valve in top bottom design

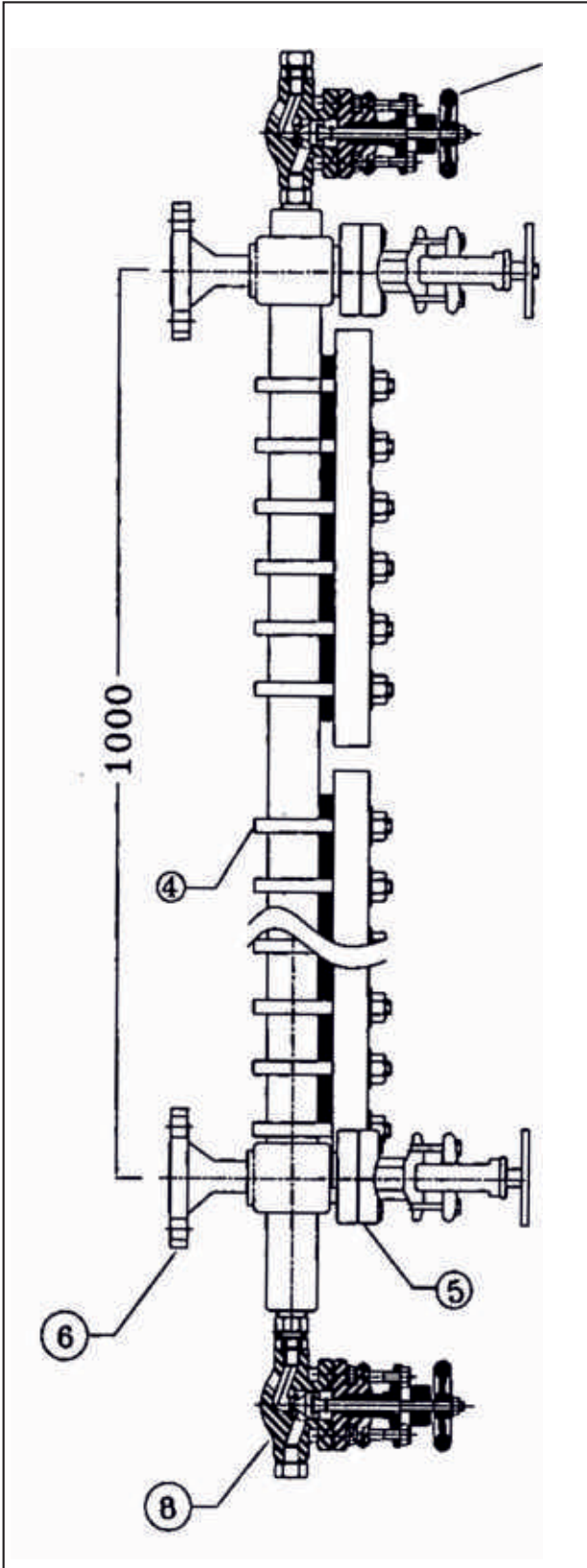

Level gauge for SS316 forged construction at 600# rating for oil and gas application with PTFE with glass sealing arrangement with forged vent and drain valves



Hydro test bench and calibration test bench applicable with helium leak test for gauges for perfect tight sealing feature

**Ordering Information**

**RLG-TBV-1000-25F150-CCC-LCC-SPP-AL-NA-Z**

