

## TR3101 Proximity 3-Wire Transmitter for Radial Shaft Vibration

The TR3101 is a cost-effective solution for monitoring the radial vibration on balance of plant machines. The TR3101 combines the proximity probe driver and the signal conditioning circuit into one package. It works with the proximity probe and extension cable as a system.

### Features

- ✓ Does not require proximity probe driver
- ✓ Buffered output/GAP will transmit signal up to 300 meters (1,000 feet)
- ✓ Compatible with other manufacturers' proximity probes (5mm, 8mm and 11mm)
- ✓ Aluminum cast (copper free) case with epoxy potting for better environmental protection and reliability
- ✓ Same size as a proximity probe driver

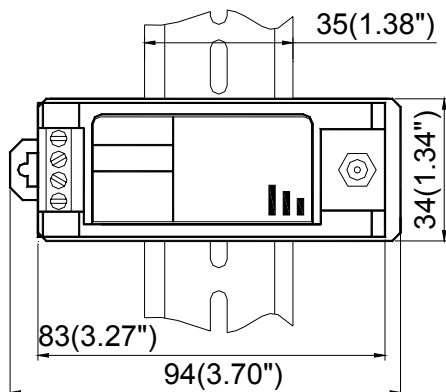

DIN Rail Mounting

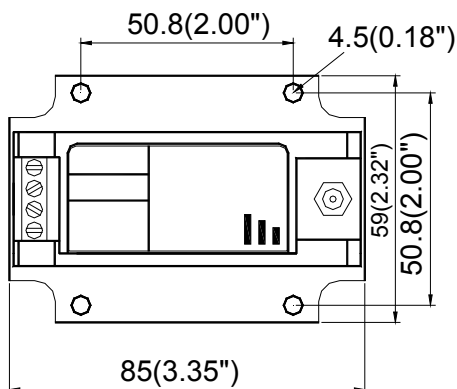

Plate Mounting



### Specifications

#### Electrical

Power Supply:

20-30VDC

Frequency Response ( $\pm 3$ dB):

2.0 - 3,000Hz

Probe and cable:

5 meter or 9 meter proximity probe and extension cable works with 5mm, 8mm, and 11mm probes

Proximity probe includes: TM0180, TM0105, TM0110, 3300, 7200, 990 series

Sensor Linear Range (reference with ANSI 4140 steel):

5mm, 8mm probe: 2.0 mm (80mil)

Approximately 0.25mm (10mil) to 2.25mm (90mil)

11mm probe: 4.0mm (160mil)

Approximately 0.4mm (15mil) to 4.4mm (175mil)

Overall Vibration:

4-20mA; Source

Buffered Output/ GAP:

Original vibration, un-filtered

Nominal: 2-18VDC

Impedance: 500 $\Omega$

Maximum cable distance: 300m (1,000ft)

Sensitivity: 8.0mV/ $\mu$ m (200mV/mil) nominal

Maximum Load:

500 $\Omega$

Isolation:

> 500Vrms; circuit to case

System OK:

System OK: output 4-20mA

System Not OK: output < 3.0mA

#### Physical

Height: 75mm (2.95")

Weight: 0.5 kg (1.0 lb)



Environmental

Temperature:

Operation: -40°C to +70°C

Storage: -40°C to +100°C

Humidity:

90% non-condensing

Order Information

\* Factory default

Standard configuration:

TR3101-A00-E00-G00-S00

8mm probe:

TM0180-07-00-05-10-02

Extension cable:

TM0181-040-00

- E12: 7200, 11mm Probe, 5m Cable
- E13: 7200, 11mm Probe, 9m Cable
- E14: 3309 Probe, 5m Cable
- E15: 3309 Probe, 7m Cable
- E16: 3000, 190 Probe, 15 Feet Cable
- E17: 3000, 190 Probe, 20 Feet Cable
- E18: 3000, 300 Probe, 15 Feet Cable
- E19: 3000, 300 Probe, 20 Feet Cable
- E20: 7200, 5mm Probe, 5m Cable
- E21: 7200, 5mm Probe, 9m Cable

GXX: Mount

G00\*: DIN rail mount

G01: Plate mount

SXX: Approval

S00\*: CE Mark

TR CU: № TC RU C-US.AA87.B.00051/18

TR3101-AXX-EXX-GXX-SXX

AXX: Full Scale

- A00\*: 0 - 200um (8.0mil) pk-pk
- A01: 0 - 500um (20mil) pk-pk
- A02: 0 - 100um (4.0mil) pk-pk
- A03: 0 - 250um (10mil) pk-pk
- A04: 0 - 630um (25mil) pk-pk
- A05: 0 - 125um (5.0mil) pk-pk

EXX: Probe and Cable (not included)

- E00\*: TM0180, 8mm Probe, 5m Cable
- E01: TM0180, 8mm Probe, 9m Cable
- E02: 3300, 8mm Probe, 5m Cable
- E03: 3300, 8mm Probe, 9m Cable
- E04: 7200, 8mm Probe, 5m Cable
- E05: 7200, 8mm Probe, 9m Cable

EXX: Probe and Cable continued

- E06: TM0105, 5mm Probe, 5m Cable
- E07: TM0105, 5mm Probe, 9m Cable
- E08: TM0110, 11mm Probe, 5m Cable
- E09: TM0110, 11mm Probe, 9m Cable
- E10: 3300, 11mm Probe, 5m Cable
- E11: 3300, 11mm Probe, 9m Cable

TR3101 Accessories

The TR3101 requires a proximity probe and extension cable to work as a system.

TM0180: 8mm probe

TM0105: 5mm probe

TM0110: 11mm probe

TM0181: Extension cable

TM900A: Din Rail Mounted Power Supply

TM0200: 3-1/2 digit display unit

BNC-3: BNC adaptor for portable data collector



Field-Wiring Diagram

